



# Spare Parts

for the edge-, corner- and stair-sanding machine

# FLIP

**Lägler**®

WORLD LEADERS IN FLOOR  
SANDING TECHNOLOGY

SPARE PARTS

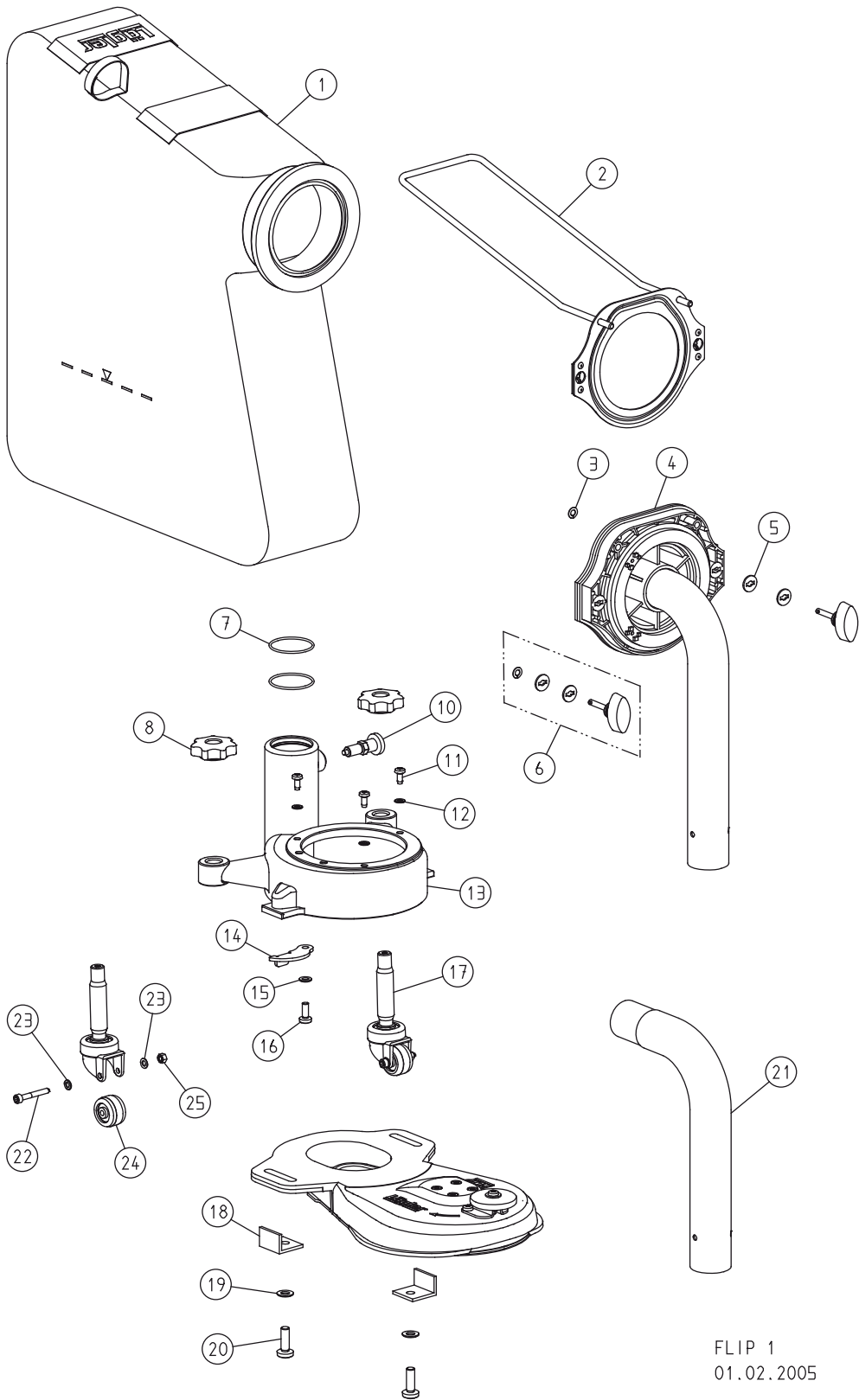

FLIP 1  
01.02.2005

## SPARE PARTS

Item	Part no.	Description
	320.00.80.100	Dust bag, complete
1	320.00.86.105	Dust bag
2	320.00.82.100	Fixing plate with bracket
3	000.25.11.752	Retaining disc
4	320.14.00.100	Pipe socket, complete
5	000.10.10.055	Washer
6	000.25.11.433	Locking pin
7	000.11.40.901	O-ring
8	320.05.11.205	Star grip (locknut)
10	000.20.15.005	Stop bolt
11	7500.1005.012	Screw
12	0125.1005.000	Washer
13	320.08.10.100	Fan housing complete
14	320.08.03.100	Belt tightener plate
15	0125.1006.000	Washer
16	7985.1006.816	Screw
17	320.05.00.200	Guide roller, complete
18	320.01.09.100	Guide angle
19	0125.1008.000	Washer
20	7985.1008.825	Screw
21	320.14.92.100	Pipe socket for vacuum cleaner connection, 38 + 40 mm outside diameter
22	0912.1005.035	Screw
23	0125.1005.000	Washer
24	320.05.09.305	Wheel
25	0980.1005.000	Nut

SPARE PARTS

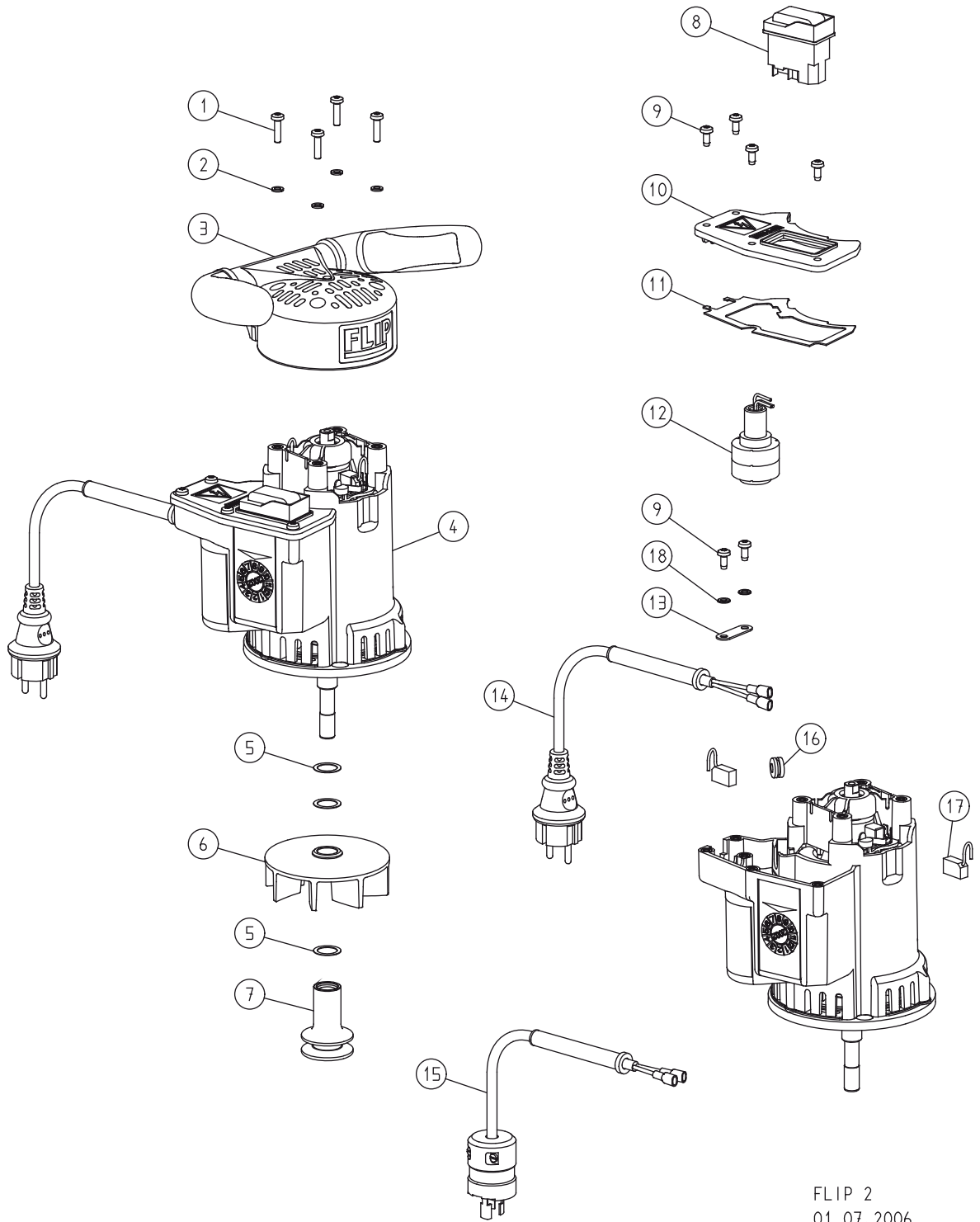

## SPARE PARTS

Item	Part no.	Description
1	7500.1005.020	Screw
2	0127.1005.000	Spring washer
3	320.20.10.105	Handle
4	320.65.00.100	Universal motor, 230 V / 50 + 60 CPS
	322.65.00.100	Universal motor, 110 V / 50 + 60 CPS, USA
5	0988.0016.005	Washer
6	320.10.10.100	Fan wheel
7	320.65.06.100	Motor belt pulley
8	000.65.60.256	Switch, 230 V / 50 + 60 CPS
	000.65.60.156	Switch, 110 V / 50 + 60 CPS
9	7500.1005.012	Screw
10	320.65.47.100	Cover switchbox with sealing
11	320.65.48.105	Sealing
12	320.65.30.100	Interference-free capacitor, complete
13	320.65.59.100	Latch fastener
14	000.65.42.151	Motor cable 2 x 1.5 mm <sup>2</sup>
15	000.65.42.153	Motor cable 2 x 1.5 mm <sup>2</sup> , USA
16	000.63.12.071	Rubber tube
17	000.65.84.012	Carbon brush
18	0125.1005.000	Washer

SPARE PARTS

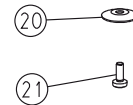
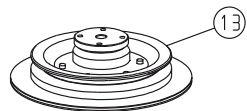
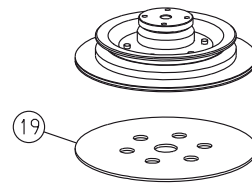
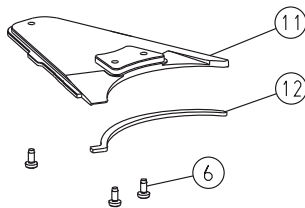
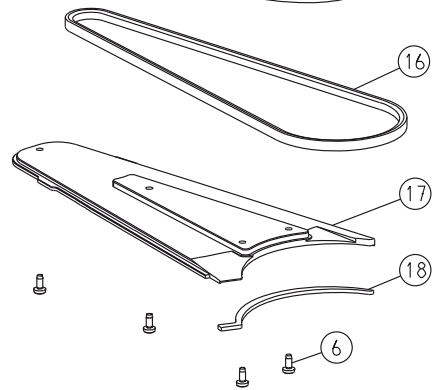
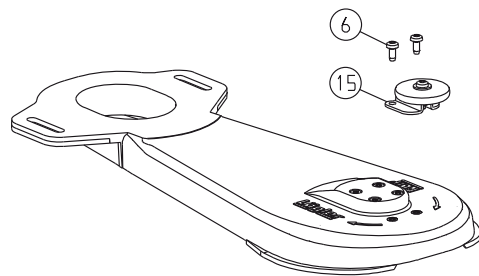
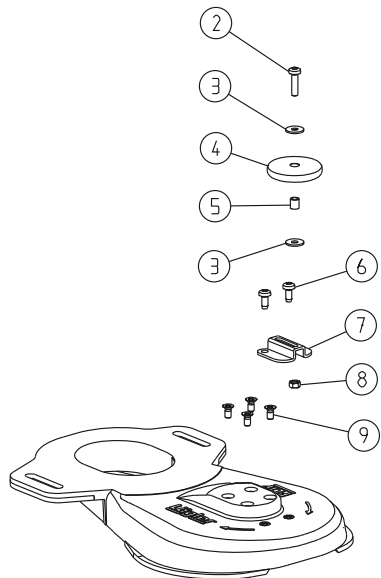
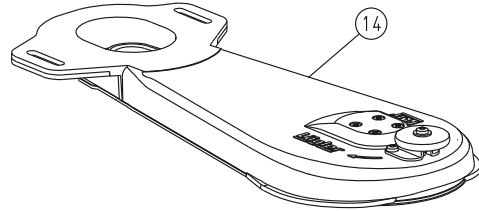
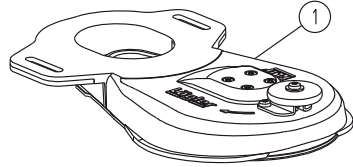

FLIP 3  
01.08.2001

Item	Part no.	Description
1	320.01.00.100	Attachment short, complete
2	7500.1005.020	Screw
3	9021.1005.000	Washer
4	320.60.02.100	Wall-protecting roller
5	000.43.15.052	Bush
6	7500.1005.012	Screw
7	320.60.01.100	Bracket
8	0934.1005.000	Nut
9	0965.1005.810	Screw
10	000.71.51.053	V-belt 10 x 530
11	320.01.03.100	Attachment cover short, complete
12	320.01.51.105	Seal, attachment cover short
13	320.01.91.100	Steel sanding plate, complete
14	330.01.00.100	Attachment long, complete
15	320.60.00.100	Wall-protecting roller with bracket
16	000.71.51.085	V-belt 10 x 850
17	330.01.03.100	Attachment cover long, complete
18	330.01.51.105	Seal, attachment cover long
19	350.03.35.205	Velcro disc 150 mm
20	320.02.05.100	Paper tensioning disc
21	7985.1006.816	Screw

SPARE PARTS

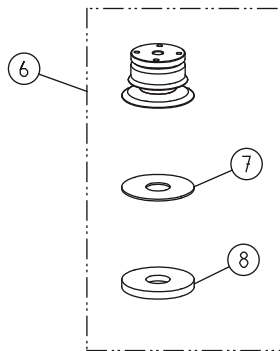
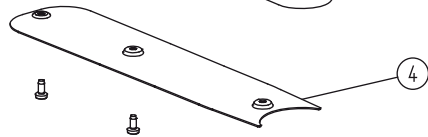
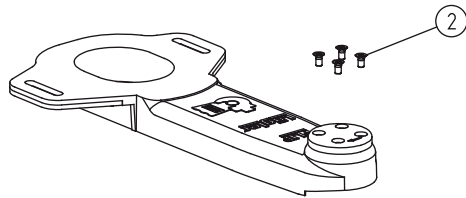
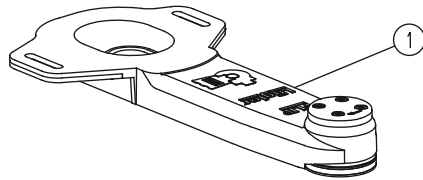

FLIP 4  
01.12.2002



## SPARE PARTS

Item	Part no.	Description
1	335.01.00.100	Corner attachment FLIP, complete
2	0965.1005.810	Screw
3	000.71.24.065	V-belt 10 x 650
4	335.01.02.100	Cover, corner attachment
5	7500.1005.012	Screw
6	335.01.91.100	Steel sanding plate for corner attachment, complete
7	335.02.12.105	Velcro disc, self-adhesive
8	335.02.13.105	Velcro ring, flexible

SPARE PARTS

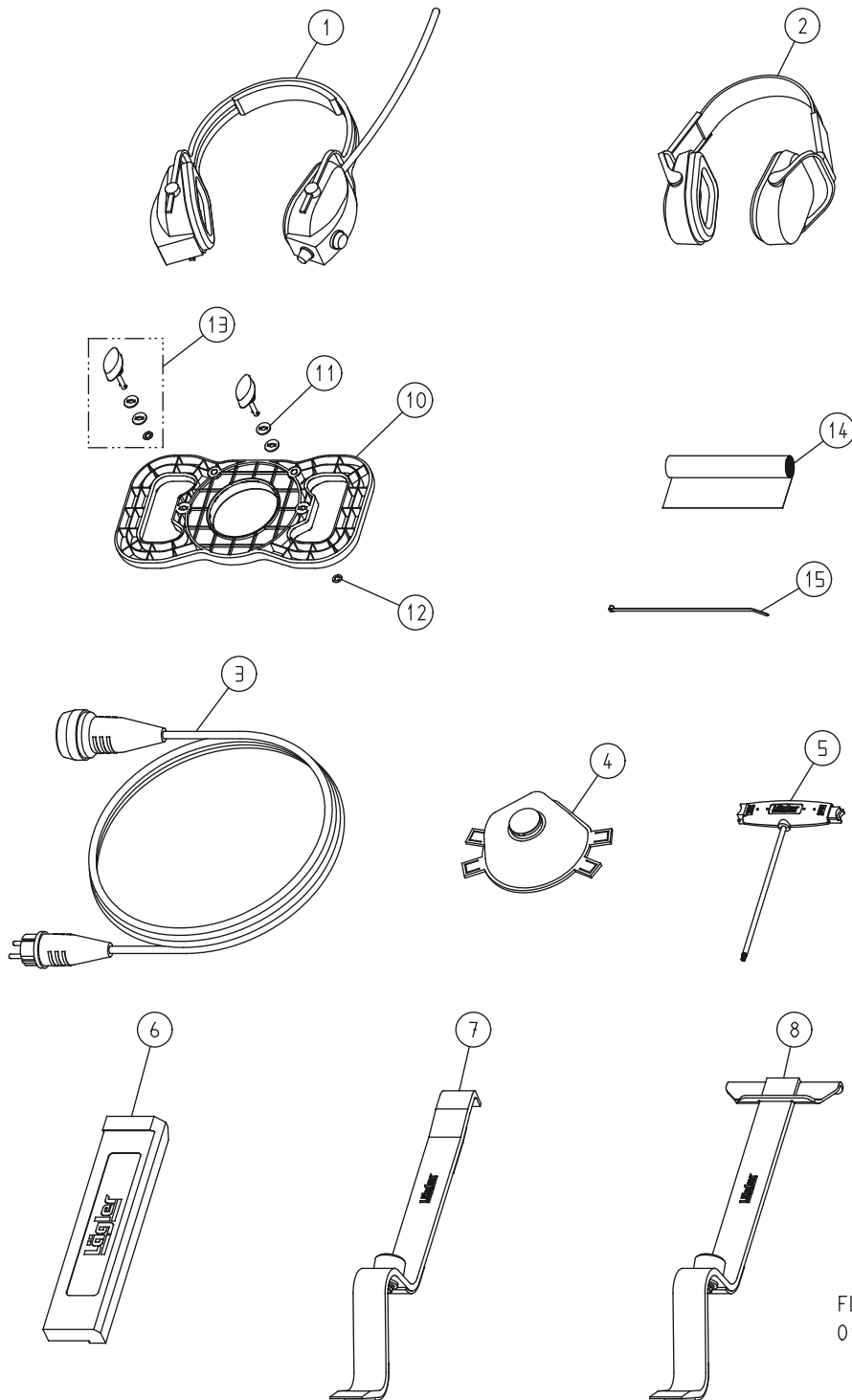

FLIP 5  
01.01.2008

## SPARE PARTS

Item	Part no.	Description
1	000.01.10.011	Foldable earmuff type MUSIMAFF
2	000.01.10.021	Foldable earmuff type POCKET
3	000.65.53.151	Extension cable 3 x 1.5 mm <sup>2</sup> , 10 m
4	000.01.20.010	Protective mask P3
5	000.91.40.001	Universal spanner
6	701.10.00.100	Impact tool
7	702.00.00.200	Parquet layer tool, small
8	703.00.00.200	Parquet layer tool, broad
10	320.00.70.100	Emptying fixture, complete
11	000.10.10.055	Washer
12	000.25.11.752	Retaining disc
13	000.25.11.433	Locking pin
14	00.000.25.570	Waste bag
15	000.61.10.363	Cable binder