

A

B

C

D

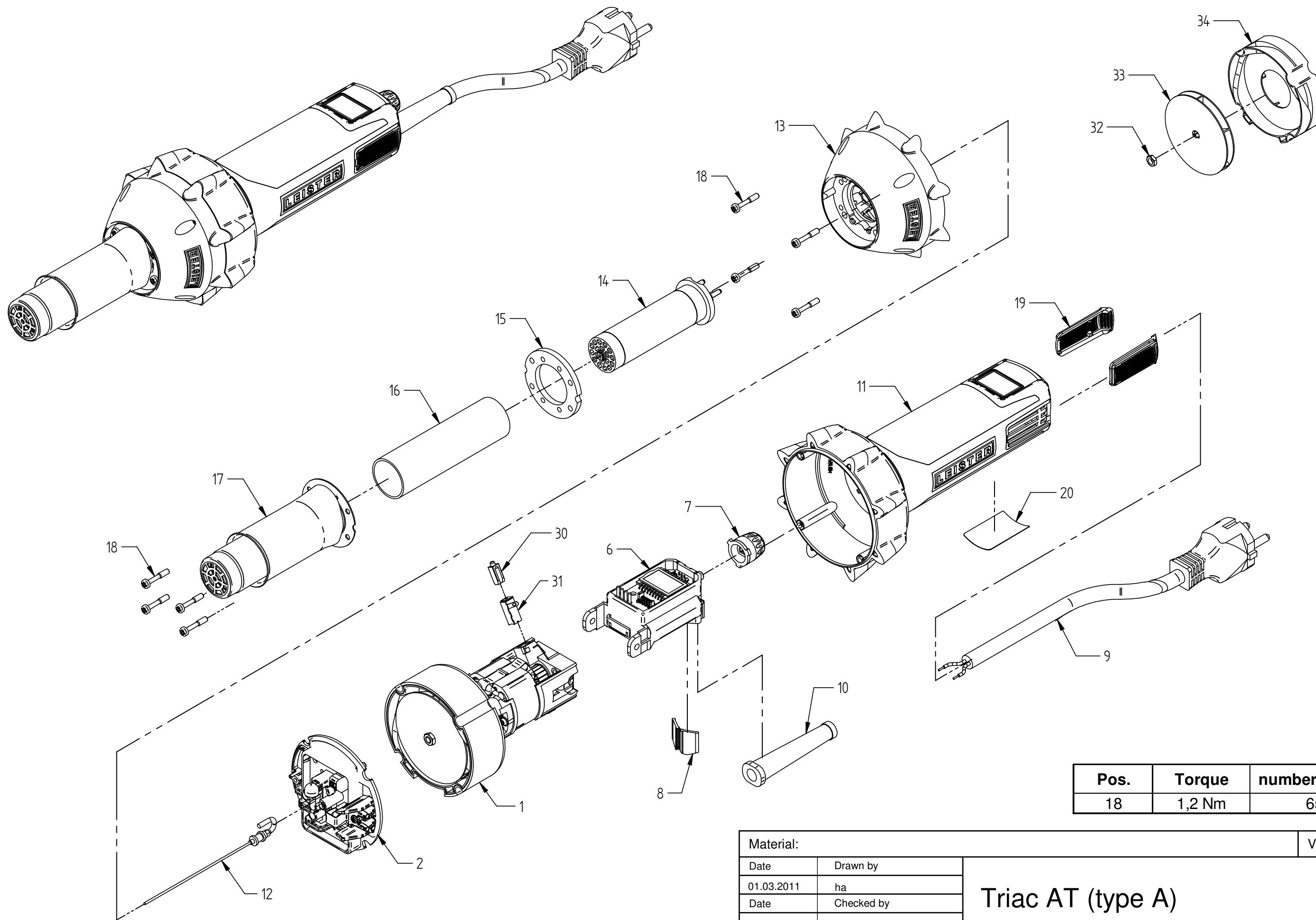

Pos.	Torque	number of revolutions
18	1,2 Nm	650 1/min.

Material:

Volume:

Date	Drawn by
01.03.2011	ha
Date	Checked by
20.09.2011	ha

Triac AT (type A)

LEISTER  
Process Technologies  
CH-6056 Kaegiswil

Format  
A3

Scale  
%

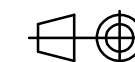

Drawing number  
020.485

Sheet  
1  
of  
1

Revision  
A